



A CSW Industrials Company

PRODUCT DATA SHEET

SAFE-T-SWITCH® SS700E  
Electronic Overflow Shut Off Switch

Description

Safe-T-Switch® Model SS700E is an overflow shut-off switch designed to fit in the auxiliary pan eliminating the need to be mounted to the pan with screws or clips. The SS700E's logic circuit continuously samples the probes for water and shuts down the system if water is detected.

Applications

Designed to sit directly in a secondary drain pan, eliminating screws and clips. Multiple position option for the sensor and provides adjustable heights. Great for use in plastic overflow pans with round edges.

Instructions

**NOTICE:** Failure to read and comply with all warnings, cautions and instructions prior to starting installation may cause personal injury and/or property damage and void the warranty.

Secondary Auxiliary Drain Pan Installation:

Disconnect power to unit at main panel.

1. Sensor Position: Place the universal puck with the sensor attached into the drain pan. Position the sensor so that the probes are facing downward and not in contact with the pan. Adjust the probe height by threading the sensor into or out of the universal puck using the supplied jamb nuts. Lock the sensor into position by tightening the nuts. Check that probes are not in contact with the pan. 2. Wire Sensor as instructed under Wiring, below. 3. Affix included warning sticker to air handler.

Wiring (see Figure 1):

**⚠ WARNING** Disconnect power to unit at main panel prior to performing electrical work.

1. In HVAC unit locate HVAC power wire going to "Wall Thermostat"(Typically red). 2. Break/Disconnect 24 VAC power wire going to "Wall Thermostat". 3. Connect "Red", Input 24 VAC( hot) and Gray "common" wire of SS700E to 24 VAC (hot) secondary side of transformer. 4. Connect "Purple" Normally closed wire of SS700E to Thermostat's "R" terminal wire. 5. Connect "Black", Input 24 VAC (common) wire of SS700E to 24 VAC (COMMON ) secondary side of 24 VAC Transformer or Thermostat's "C" terminal.



Characteristics | Features

- Works in any position
- Universal puck works in all secondary drain pans
- Onboard LED indicator
  - ◊ Red LED - Overflow detected
  - ◊ Green LED - No overflow detected
  - ◊ Yellow LED - Overflow previously detected in last 4 days
- State-of-the-art microelectronics
- Automatically resets once water subsides, no drying required
- No moving parts
- 5-wire design
- 24 V 5A, high current-carrying capacity
- Adjustable sensitivity



Packaging

| Code  | Description  | Qty. per Case | Lbs. per Case | Cubic Ft per Case |
|-------|--------------|---------------|---------------|-------------------|
| 97695 | Model SS700E | 24            | 13.95         | 0.92              |

## Wiring Diagram

Figure 1: Wiring Diagram for Unit Shutdown

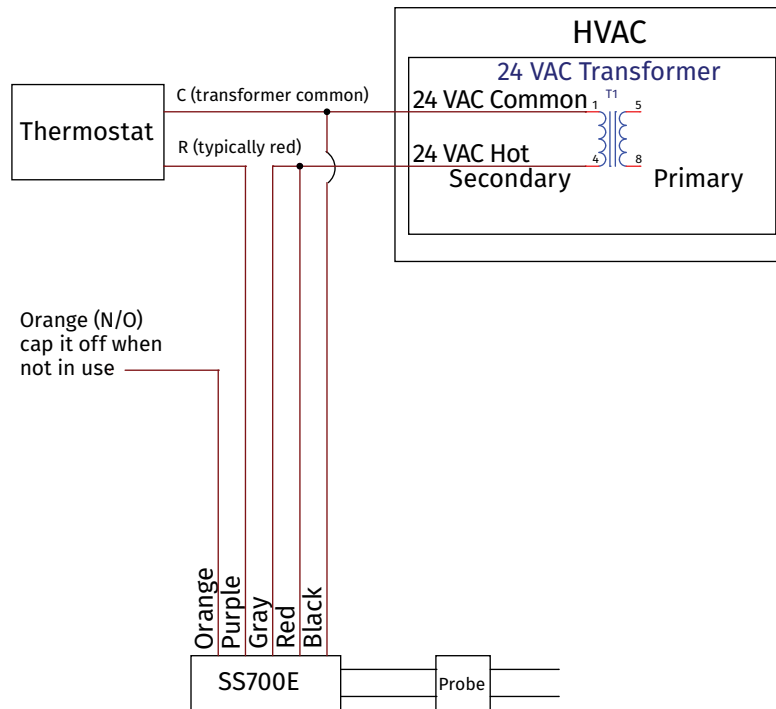

## Testing (Turn on Power to AC Unit):

### Switch:

1. Once installed and the power is turned on and the **COMPRESSOR IS RUNNING**, the CPU will display a flashing green LED. If the green LED does not come on, reverse the switch leads.
2. Test the sensor position: Test the sensor position by filling the auxiliary pan with water. Adjust the sensor so that the switch will activate at a preferred water depth but before the pan overflows.
3. Test the switch by shorting across the probes with your finger or water. If wired correctly, the unit will stop and the red LED will come on after 5 seconds. When released, after 5 seconds the red LED will go off, the green and amber LEDs will come on and the AC unit will restart. If the switch does not cycle, try shorting across the probes with a metallic conductor or water. To turn off amber light, see manual history reset tag on CPU wire.

**WARNING** The device must be installed strictly in accordance with manufacturer's instructions (to ensure proper operation) and in accordance with all applicable local plumbing, drainage and electrical codes.

**WARNING** ELECTRIC SHOCK HAZARD. Disconnect power supply before installing this product to avoid electrical shock and/or equipment damage. Use in Class 2 (thermostat) circuit only, not to exceed 24 volts, 5 amps to avoid damage of fire hazard.

**WARNING** Use the SS700E as a stand alone switch only. It is not designed for use with any other switch device.

**CAUTION** This product is intended for use in water only. Not for use in the presence of flammable liquids or vapors.

**CAUTION** Refer to the appropriate HVAC equipment operation manual prior to installing this product.

**CAUTION** Do not use on dual compressor systems.

# SAFE-T-SWITCH® SS700E

Electronic Overflow Shut Off Switch

Specifications: 24-Volt A/C, 5 Amp. Switching Capacity, Class 2, 72", 18 AWG Lead Wires, & 24" tail.

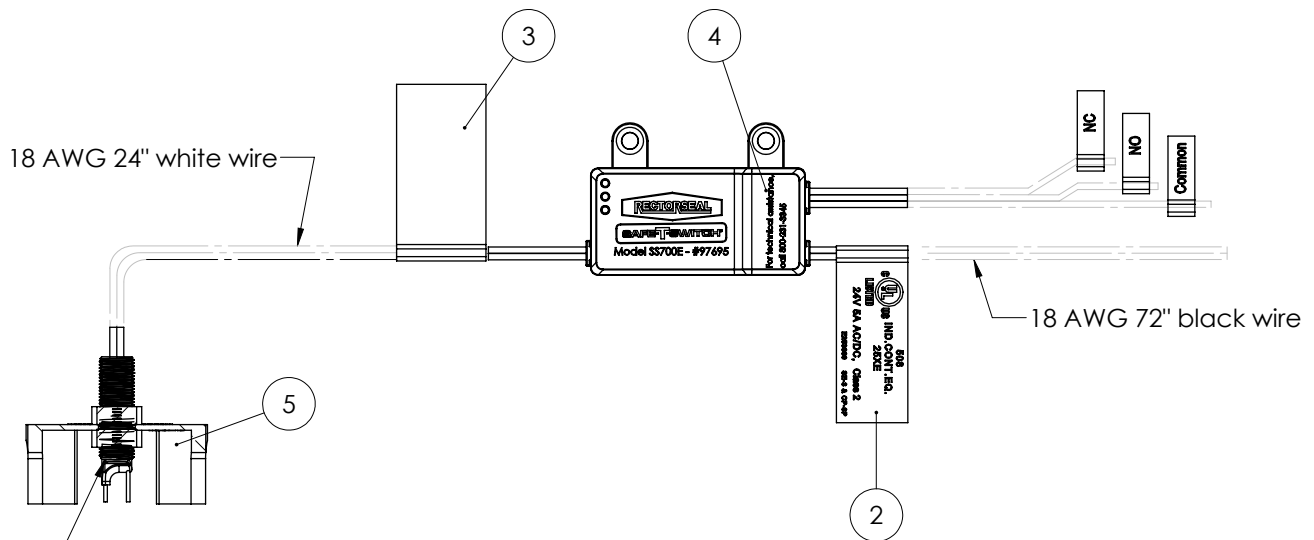

1. SE-3 Probe
2. UL Tag, SE-3 & SP-1P
3. Reset Instruction Tag
4. Central Processing Unit CP-1P
5. Puck Style bracket BK-7P

Manufactured by

**RectorSeal, LLC**

**2601 Spenwick Drive • Houston, TX 77055, USA • 800-231-3345 • Fax 800-441-0051 • [rectorseal.com](http://rectorseal.com)**

A CSW Industrials Company. RectorSeal, the logos and other trademarks are property of RectorSeal, LLC, its affiliates or its licensors and are protected by copyright, trademark and other intellectual property laws, and may not be used without permission. RectorSeal reserves the right to change specifications without prior notice. ©2020 RectorSeal. All rights reserved. R50109-0620